

Low Pass Filter Kit

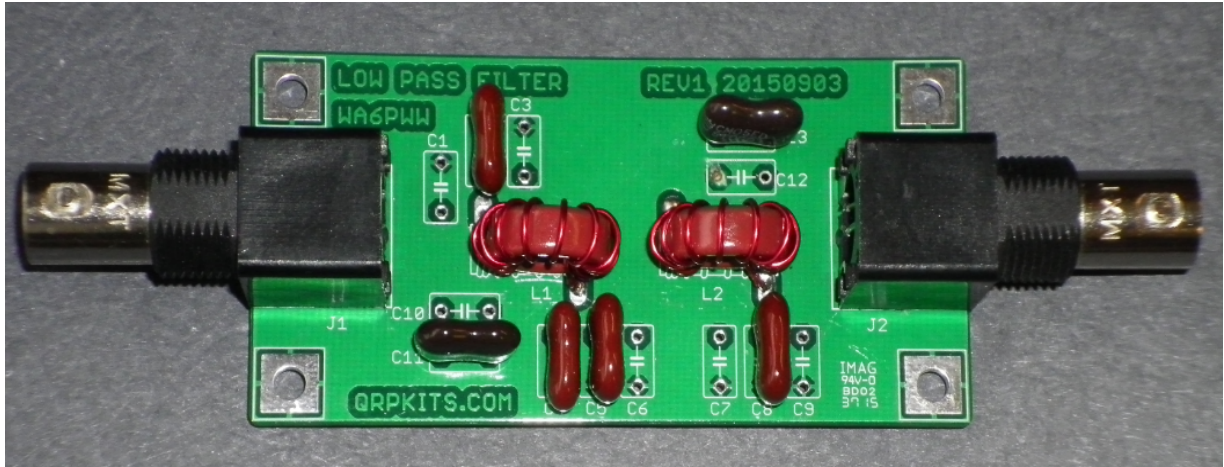

Description

Many basic transmitter and/or transceiver designs have minimal filtering on their output and frequently significant harmonic content in their signals.

Our Low Pass Filter kit from qrpkits.com provides an inline, 5 pole LC filter for reducing those harmonics and other spurious signals.

Our Low Pass Filter includes capacitors in parallel with inductors that resonate them on the second and third multiple of the design frequency thus further attenuating harmonic energy.

When properly configured, our low pass filter is capable of significantly reducing harmonics of a transmitter, amplifier or any other signal source with minimal effect on the desired signal.

Specifications

Power handling up to 100W under matched conditions

Reduction of harmonics by more than 50dB

Constructed on a 1.75x 3.5 inch printed circuit board

Designed to be placed inline between a transmitter or transceiver and antenna

Includes board mounted BNC connectors and all necessary parts

Support

PACIFIC ANTENNA

QRP KITS.COM

qrpkits.com@gmail.com

Tools Needed

- Temperature Controlled Soldering Station with small tip or 15-35 watt soldering iron with small tip.
- Solder 60/40 or 63/37 Tin-Lead
- Small Diagonal Cutters
- Small Needle Nose Pliers
- Pencil, Pen, and/or Highlighter
- BRIGHT work light

Optional

- Magnifying headpiece or lighted magnifying glass.
- Multi-meter
- Solder Sucker or Solder Wick
- Small multi-blade Screw Driver
- Knife or Wire Stripper
- Small Ruler
- Cookie Sheet to build in and keep parts from jumping onto the floor.

Construction Techniques

- Please take time to inventory the parts before starting. Report any shortages to QRPKITS.com (In many cases it may be faster and cheaper to pull a replacement from your parts supply, but please let us know if we missed something.)
- Pre-sorting the resistors and capacitors can speed up the assembly and reduce mistakes.
- There is no need to print out the whole assembly manual unless you want a copy. Print the Parts List and Schematic (last two pages) then view the rest of the manual on a computer, laptop, or tablet. The Parts List has columns for inventory and construction.
- You can insert several parts at a time onto the board. When you insert a part bend the leads over slightly to hold the part in place, then solder all at the same time. Clip the leads flush.
- Most parts should be mounted as close to the board as possible. Transistors should be mounted about 1/8" above the board. Solder one lead on ICs or IC sockets and then check to make sure the component is flush before soldering the remaining leads.
- Use a Temperature Controlled Soldering Station with small tip or 15-35 watt soldering iron with small tip. Conical or very small screw driver tips are best.
- DO NOT use a large soldering iron or soldering gun.
- If you are a beginner, new to soldering, there are a number of resources on the web to help you get on the right track soldering like a pro. Google Soldering Techniques. Here is one good example: http://www.elecraft.com/TechNotes/NOSS_SolderNotes/NOSS_SolderNotesV6.pdf

Printing the Manual

Note: There is no need to print out the whole assembly manual unless you want a copy. Print the Parts List and Schematic then view the rest of the manual on a computer, laptop, or tablet. The Parts List has columns for inventory and construction.

Inventory and Parts List

Please take time to inventory the parts before starting. Report any shortages to QRPKITS.com (In many cases it may be faster and cheaper to pull a replacement from your parts supply, but please let us know if we missed something.)

Use the first column of the table below to check the parts as you inventory them and use the second column to check the parts as you install them.

Parts

Inven.	Installed	Part #	10M +12M	15M +17M	20M	30M		80M	160M
		PCB	1	1	1	1	1	1	1
		BNC J1, J2	2	2	2	2	2	2	2
		C1, C2 or C3	TBD	TBD	150pF	180pF	270pF	1000pF	TBD
		C7, C8 or C9			150pF	180pF	270pF	1000pF	
		C4, C5 or C6			300pf or 2x 150pF	360pF or 2x 180pF*	560pF	1800pF	
		C10			22pF	27pF	22pF	100pF	
		C11			N/A	N/A	22pF	N/A	
		C12			51pf	33pF	51pF	270pF	
		C13			N/A	33pF	51pF	N/A	
		L1	T50-6	T50-6	11 turns T50-2	14 turns T50-2	16 turns T50-2	21 turns T50-2	T50-2
		L2	T50-6	T50-6	11 turns T50-2	14 turns T50-2	16 turns T50-2	19 turns T50-2	T50-2
		#22 Wire			2ft	2.5ft	3ft	5ft	

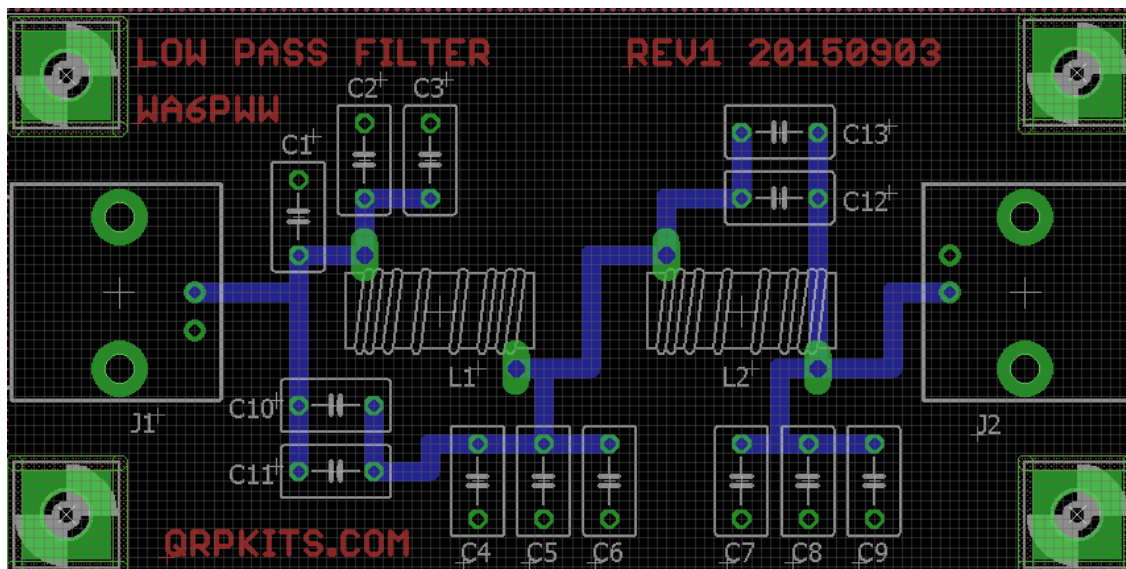

Inserting the Parts

Install the components listed in the table for the band chosen. The parts layout on the previous page shows the locations.

Install BNC connectors

Note: If you plan to mount this kit in a case or build into another assembly where input and output connectors will not be needed or mounted on the case you may not want to install the on board BNCs.

- 1) Solder the supplied BNC connectors on each end of the board in the positions marked J1 and J2. Be sure that the connectors are fully seated and then solder the support pins one at a time.
- 2) After the first support pin is soldered, recheck that the connector is seated on the board. If not, reheat the connector support pin while pressing down on the board to fully seat it. Once the connectors are seated and both support pins are soldered, go ahead and solder the two signal connection pins (smaller) on each BNC.

Wind and Install Toroids for L1 and L2

Wind the toroids to create inductors L1 and L2 to the specified number of turns specified in the parts list.

Remember that each pass through the center of the toroid counts as 1 turn.

Spread the turns uniformly around the toroid, leaving space for the ends of the windings to align with the circuit board holes.

The wire supplied is heat strippable and you can tin the ends of the wires using either the solder blob technique or by first sanding or scraping the insulation from the wires to expose the bare copper and then tinning with solder.

Install L1 and L2 in the circuit board holes and pull the wires gently to remove slack and hold the toroids close to the board.

Solder L1 and L2 in place.

Capacitors

Install the appropriate value capacitors in positions C1 through C13 as indicated in the table.

Note: not all positions will always be filled with capacitors. The additional capacitor locations are there so that multiple capacitors may be paralleled to give the needed value for a particular frequency of operation.

Checkout:

Inspect the board for any bad solder joints, shorts or other problems and correct before use.

Using a multimeter in resistance mode, measure the resistance between the center pins of input and output BNC connectors (or pads on the board if BNCs are not installed). The value should be low, usually less than 1 ohm and confirms that the components are in place and leads connected.

Check from the BNC center to shell (or across the input or output pads if BNCs not installed). There should be a very high resistance, probably infinite reading on the DMM resistance scale. This confirms that there are no shorts to ground.

Congratulations, you have now completed the assembly of your low pass filter kit!

Packaging

Packaging is left up to the builder. The kit can be built into another assembly or installed in a case for stand alone operation.

Usage

The low pass filter is placed inline following a transmitter, transceiver or other signal source. It has minimal attenuation of signals below the designed cutoff frequency and will provide attenuation above the design frequency with notches at the second and third harmonics to provide attenuation.

Adding a low pass filter tuned to the band of operation will clean up a transmitter or amplifier that has little or no filtering or which can benefit from increased attenuation of signals above its operating frequency.

This can be very helpful for reducing interference between nearby stations on different bands such as during field day or contests. For example, using the 40M LP filter on a 40M station will reduce harmonic energy and reduce its interference to other nearby stations operating on higher bands such as 20M.

Schematic Diagram

